



HARMONIA
LIVING

Urbana Wedge End Table HL-URBN-CB-WET

Product Images



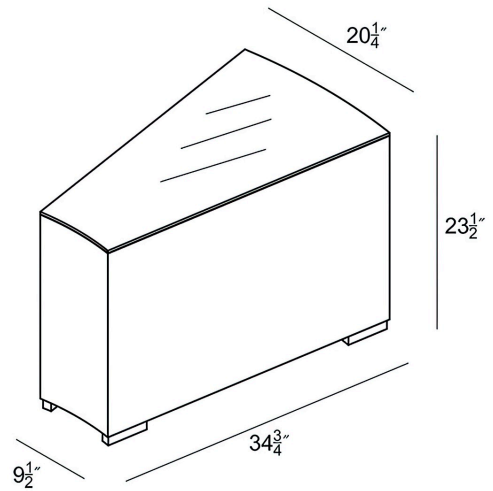

Description

The Urbana Wedge End Table by Harmonia Living will bring additional style and practicality to your outdoor patio set. This collection's modern design and beautiful wicker give it a unique visual appeal, while sturdy, all-weather construction ensures lasting performance across the seasons. The wicker is made with durable High-Density Polyethylene (HDPE) and finished in a beautifully textured Coffee Bean color, which gives it a natural feel. A clear tempered glass top makes cleaning an easy task, while its thick-gauged aluminum frame provides a Staple, durable foundation for your new table.

Includes

- 1x Urbana Wedge End Table (HL-URBN-CB-WET)

Dimensions

- Urbana Wedge End Table: 34.75"L x 20.25"W x 23.5"H (35 lbs.)
- Frame Height: 23.5"

Features

- Wicker is hand-woven onto a thick gauge, powder coated aluminum frame that is lightweight, durable and corrosion resistant.
- Decorative brushed aluminum feet
- Plastic foot glides help to protect your patio from scratching and also to help keep the furniture protected from dirt or water that can accumulate on the patio.
- Hydraulic lift lid makes opening easy.